

# Boot-Lift® Railcar Connector



The **Boot-Lift® Railcar Connector** installs on the track flanges. Sponge seals fit securely to the hopper car unloading gates for a clean transfer of material to the under-track conveying system.

## SPECIFICATIONS

<b>Controls</b>	All assemblies include the appropriate control console.
<b>Air Requirements</b>	1 cfm (0.47 L/sec) at 90 psi (6.2 bar). Air line should include filter, regulator, and lubricator.
<b>Boot Material</b>	Standard material is 22 oz. black vinyl-covered cloth. Other materials are available, including polyethylene lined; white hypalon-coated cloth; food-grade polyethylene-lined polypropylene; and flame retardant coated polyester.

## ACCESSORIES

- TRANSITION FUNNELS**

These convert various models from double- to single-pocket unloading or from single- to double-pocket unloading. Simply remove the standard sponge seals and install the appropriate transition funnel and adapter sheet.

DBL Transition Funnel..... P/N 17272

DBL Adapter Sheet.....P/N DBL-18AS

Converts DBL and DBL-GATX to SBL; requires DBL Adapter Sheet to fit opening.

- ADAPTER SHEETS**

Rugged plywood adapters provide the proper discharge opening to suit various cars. Consult your Martin Engineering representative for specific adapter sheet requirements.

SBL Adapter Sheet.....P/N SBL-24AS

SBL Adapter Sheet.....P/N SBL-30AS

- MANUAL ALIGNER**

Simplifies car positioning by allowing manual adjustment of up to 6 in. (150 mm) total—3 in. (75 mm) in either direction—along the track.

Boot-Lift® Manual Aligner.....P/N 17326

- PNEUMATIC ALIGNER**

Air-powered aligner provides 8 in. (200 mm) of adjustment—4 in. (100 mm) in either direction—along the track. Remote control; requires only 1 cfm (0.47 L/sec) at 30 psi (2 bar) of air. Boot-Lift® Pneumatic Aligner.....P/N 34140

- CYLINDER COVERS**

Rugged vinyl-covered cloth covers prevent damage and contamination of air cylinders from material buildup and environmental conditions.

Lift Cylinder Covers.....P/N 18335

Spread Cylinder Covers.....P/N 18331

- FUNNEL COVERS**

SBL-24.....P/N 19544

SBL-30.....P/N 34884-CA

DBL-18/DBLG-18.....P/N 18420-01

- REPLACEMENT PARTS**

Replacement boots, sponge seals, and other components are available; see your Martin Engineering representative for more information.

# TECHNICAL DATA SHEET

## DIMENSIONS—in. (mm)

Model	A	B		C	D	E	F Funnel Opening
		Extended	Retracted				
SBL-24	57 (1448)	18.5 (470)	4.50 (115)	42.26 (1073)	54 (1372)	29.1 (740)	22 (559)
SBL-30	57 (1448)	18.5 (470)	4.50 (115)	50.26 (1277)	54 (1372)	37.1 (943)	30 (762)
SBLR-18	57 (1448)	22.23 (565)	6.03 (153)	36.26 (921)	48 (1219)	23 (584)	Ø 15 (381)
DBL-18	57 (1448)	21.56 (548)	5.34 (136)	36.26 (921)	54 <sup>†</sup> (1372)	23.1 (587)	12.5 (318)
DBL-18-GATX	57 (1448)	21.93 (557)	5.71 (145)	36.26 (921)	54 <sup>††</sup> (1372)	23.1 (587)	12.5 (318)

<sup>†</sup>Extended 69 in. (1752.6 mm)    <sup>††</sup>Extended 76.63 in. (1946.4 mm)

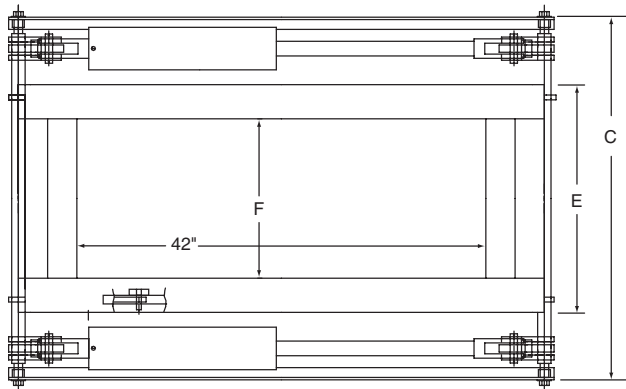

SBL-24, SBL-30

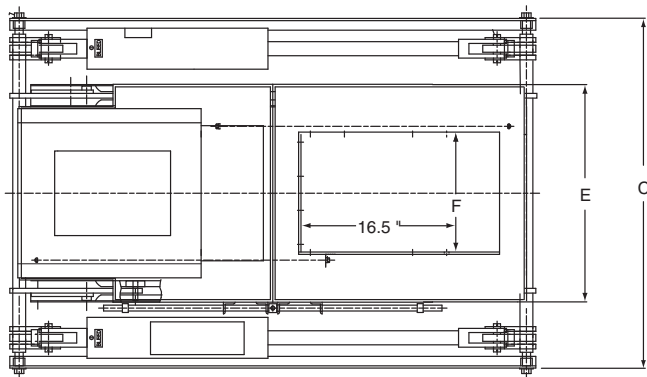

DBL-18, DBL-18-GATX

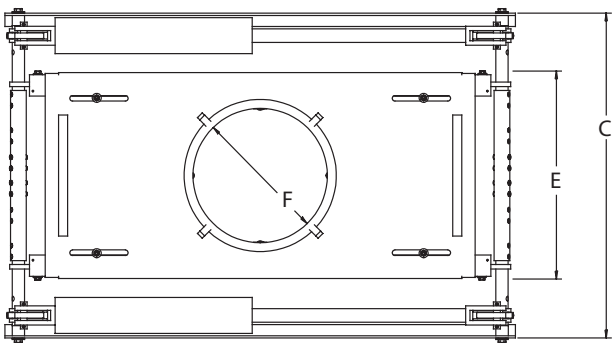

SBLR-18